



Concord

Trade

The Concord Cubicle System - SGL Trade Range designed for optimal durability, maximum value

GARRAN

Robust SGL panel cubicle system for high traffic and wet area washrooms

Specification

Pilasters/Divisions/Doors:

Panel Spec Options:

- SGL Core/Face: Solid grade laminate with colour finish to both sides giving 13mm nominal thickness
- Edge: Polished and radiused

- Colour: From the Garran Washroom colour selector

Hardware:

All fittings manufactured from high quality SAA aluminium

- Pedestals: Concord SAA round legs with adjustable height to accommodate uneven floors
- Hinges: Ultra durable twin bolt-thru hinges - 2nr per door
- Indicator Bolt: Pilaster mounted, anti-vandal, flip latch machined from PPC Aluminium
- Partition Fixing: Partitions secured with aluminium D brackets and stainless steel bolt-thru fixings
- Headrail: D section headrail for maximum strength

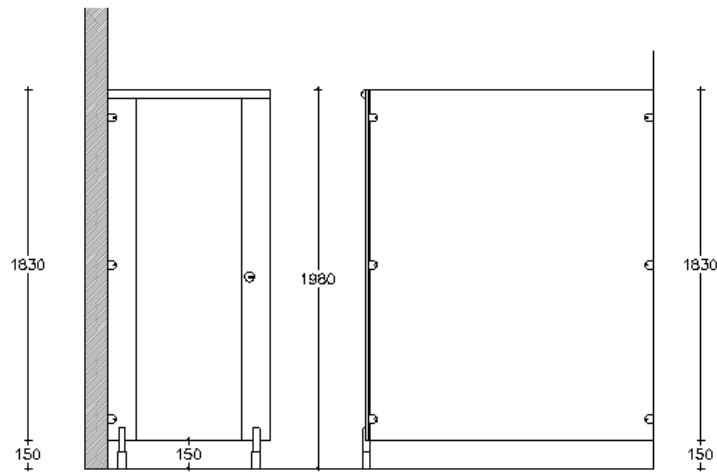

Typical Cubicle Elevations

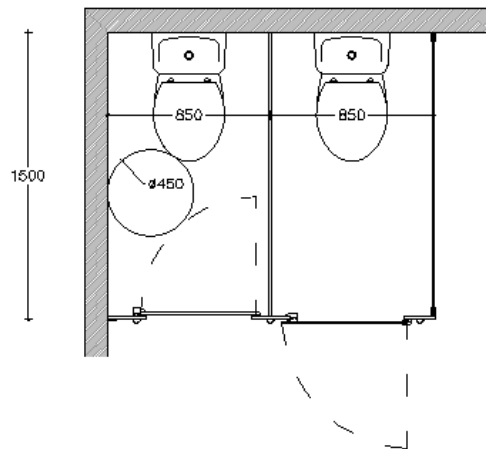

Suitable for sectors

▶ Sports & Leisure

▶ Education

▶ Industrial

▶ Office

▶ Transport

Dimension Details:

- Overall Height: 1980mm
- Widths: from 700mm
- Floor Clearance: 150mm
- Depth: 1500mm standard
- Panel thickness: 12/13mm

Complementary Options:

- Vanity Units and IPS Duct Panel Systems